

Crio Tech 800 1 door prostore refrigerator 720L, 0+10°C, R290

ITEM # _____

MODEL # _____

NAME # _____

SIS # _____

AIA # _____



729531 (APS06R1FHC)

1-door prostore refrigerator
720L, 0+10°C, (R290), AISI
304

Short Form Specification

Item No.

Full door refrigerator constructed in 304 AISI stainless steel with external bottom panel in anti-corrosive material. Large digital display featuring humidity selection button (3 preset level), cabinet temperature display and setting and turbo frost cycle (to rapidly cool warm loads). HACCP-compliant control with alarms and history. IQ defrost to defrost only when required with automatic evaporation of defrost water. Optimized airflow provides even temperature distribution on all grids. Fitted with 65 mm-thick polyurethane insulating foam. Self-closing, on-site reversible door features microswitch to switch off the fan when the door is opened. Hidden evaporator to guarantee higher storage capacity and less corrosion problems. Built-in refrigeration unit; ventilated operation; Interior LED light. For ambient temperatures up to 43 °C. CFC and HCFC free. R290 highly ecological refrigerant type, cyclopentane gas in foam.

Supplied with 4 x 700x530mm Rilsan coated grids and n. 4 sets of 2 stainless steel grid runners. Prearranged to fit RS485 port to facilitate connection to a remote computer and integrated HACCP systems.

Main Features

- Large digital white-digit display with humidity selection button (3 preset level), cabinet temperature display and setting and turbo frost cycle (to rapidly cool warm loads).
- IPX5 frontal water protection.
- Connectivity ready for real time access to connected appliances from remote and data monitoring (requires optional accessory).
- Fully compliant HACCP digital control: when temperature exceeds critical limits, acoustic and visual alarms are activated. Up to two months of event are kept in memory.
- Large storage area suitable to contain 700x530 mm grids to improve net capacity.
- Optimized airflow within the chamber guarantees uniformity of temperature on all grids.
- IQ Defrost: fully automatic defrost starts only when ice is actually building-up in the evaporator.
- Hidden evaporator thus guaranteeing higher storage capacity and less corrosion problems.
- Greater storage space: internal structure with numerous charging positions available to host grids, ensuring higher net capacity.
- Adjustable temperature range from 0°C to +10°C.
- Model requires only 1 phase 230V/50Hz supply and can be plugged straight into an existing power socket.
- Prearranged to fit RS485 port to facilitate connection to a remote computer and integrated HACCP systems.
- Complies with main international certification bodies and is CE marked.
- High resistance foot pedal included.
- Self closing and on site reversible left/right doors.
- This appliance is intended for use in ambient temperatures up to 40°C.
- ECA listed.
- Tropicalized unit.
- Large digital white-digit display with cabinet temperature display and setting, and possibility to select the desired levels of humidity. Bluetooth technology included allows to keep HACCP historical data and download them through the app.
- Alpeninox Fridge Control APP make the life easier for our customers:
 - Monitor safety of preservation process thanks to HACCP data & alarms for precise control
 - Save time and easy data management having the possibility to send the HACCP information in excel format directly to e-mail address
 - Quick operations: set the cabinet temperature/humidity/turbocooling and set date/hour

APPROVAL: _____

Construction

- Stainless steel AISI 304 external panels (galvanized external back).
- Inner cell with rounded corners, bottom pressed in only one piece.
- Stainless steel runners and supports easily disassembled.
- Internal components removable without the use of tools to facilitate cleaning operations.
- Pressed stainless steel door handle without joints gathering dust and dirt.
- Easy access to the main components for maintenance.
- Developed and produced in ISO 9001 and ISO 14001 certified factory.
- Lockable door.

Sustainability

- CFC and HCFC free, highly ecological refrigerant type: R290 (ecological gas in foam: cyclopentane). Hydrocarbon refrigerant gas R290 for the lowest environmental impact (GWP=3), to reduce green house and ozone depletion effects.
- Insulation thickness: 65 mm of polyurethane injected with ecological foaming gas cyclopentane to ensure effective insulation with minimum energy consumption (thermal conductivity: 0,020 W/m*K).
- Removable triple-chamber balloon magnetic gasket to improve insulation and reduce energy consumption and ease of cleaning.
- Cleaning-free condenser: the structure of the wire frame condenser prevents dust and grease accumulation thus avoiding periodical cleaning operations and reducing energy consumption.
- Optical door microswitch to stop the fan once the door is opened, thus minimizing energy waste.
- Interior LED light to save energy and for best internal visibility.

Included Accessories

- 1 of Pedal opening for cabinets PNC 880324
- 5 of Pair of runners for 470L and 720L prostore cabinets PNC 880335
- 5 of Plastic-coated grid 700x530mm for Prostore 720I PNC 880343

Optional Accessories

- Stainless steel grid 2/1GN for prostore cabinets PNC 880160
- 2/1GN plastic-coated grid PNC 880306
- Pair of runners for 2/1GN grids, for prostore cabinets PNC 880320
- Stainless steel grid (700x530) PNC 880323
- Pedal opening for cabinets PNC 880324
- Kit 4 feet, height 200mm PNC 880325
- Kit of 4 feet-h=67 (marine) PNC 880326
- Kit pair of runners (marine) PNC 880327
- Pair of runners for 470L and 720L prostore cabinets PNC 880335
- Plastic-coated grid 700x530mm for Prostore 720I PNC 880343



Front

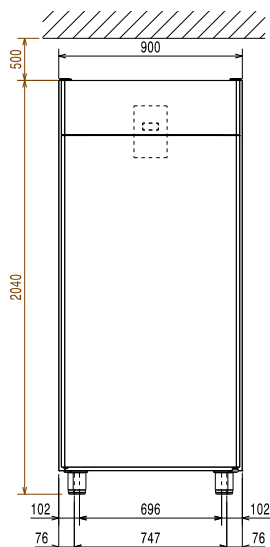

Side

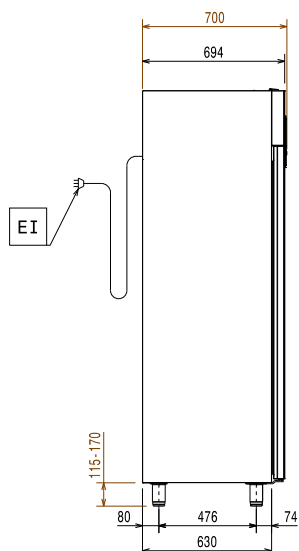

EI = Electrical inlet (power)

Top

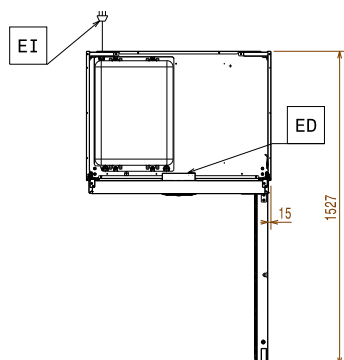

Electric

Supply voltage:	220-240 V/1 ph/50 Hz
Electrical power max:	0.17 kW

Capacity:

Number and type of grids (included):	5 - 530x700
--------------------------------------	-------------

Key Information:

Net Volume:	510 lt
Door hinges:	
External dimensions, Width:	900 mm
External dimensions, Depth:	700 mm
External dimensions, Depth with Doors Open:	1527 mm
External dimensions, Height:	2040 mm
Number and type of doors:	1 Full
Internal Dimensions, Width:	772 mm
Internal Dimensions, Depth:	582 mm
Internal Dimensions, Height:	1436 mm
Height adjustment:	15/40 mm
Type of external material:	304 AISI
Type of internal material:	304 AISI
Number of positions & pitch:	44; 22 mm
Gross capacity:	720 lt
Type of model (EU Regulation. 2015/1094):	vertical chilled

Refrigeration Data

Control type:	Digital
Refrigeration power at evaporation temperature:	-10 °C
Operating temperature min.:	0 °C
Operating temperature max.:	10 °C
Compressor power:	1/4 hp
Operating mode:	Ventilated
Cooling unit:	Built-In
Defrost type:	By Air

Sustainability

Noise level:	52 dBA
Refrigerant type:	R290
GWP Index:	3
Refrigeration power:	406 W
Refrigerant weight:	115 g
Energy Class (EU Reg. 2015/1094):	B
Yearly and daily energy consumption (EU Reg. 2015/1094):	506kWh/year - 1kWh/24h
Climate class (EU Reg. 2015/1094):	Heavy Duty (5)
Energy Efficiency Index-EEI (EU Reg. 2015/1094):	34.96

EU energy labelling from 1st July 2016

The European energy labelling scheme for professional refrigerators and freezers is based on requirements setting Minimum Energy Performance standards for commercial refrigeration cabinets sold within the EU. These requirements are designed to drive energy efficiency and environmentally friendly approach for professionals. The European energy labelling scheme will apply to all manufacturers and importers who sell and market products within the EU and it is mandatory across Europe. Important: all products which consume energy above the minimum level will not be able to be sold within the EU from 1 July 2016.

SI 2020 No. 1528.

Important: all products which consume energy above the minimum level will not be able to be sold within the EU from 1 July 2016.

